

# Adjustable Automatic Master Potato Baler

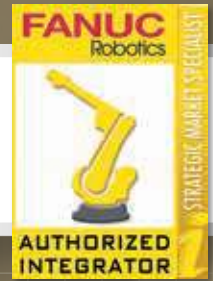

**AB-3000HS**  
**High Speed Model**

Shown with optional Alignment Conveyor, Bypass System and FuseAire 4 Hot Air Sealer.

Change from poly to paper master bags in minutes!



**Designed to handle more gently than hand baling**

- Multi Stage Accumulation Chamber reduces drop
- Padded Infeed
- Padded Reciprocator
- Air Cylinder Dampening on Discharge Gates
- Computer Driven Bag Saddle Deceleration
- Air Cylinder Dampening on Bag Saddle
- Bag Sense ensures Master Bag is in place avoiding spills and damage
- Filled Bale Bag positively controlled avoiding spills

**Only the AB-3000HS JMC offers all these features!**

- Counts and accumulates both poly and paper bags
- Accepts all bag sizes from 3 lbs to 20 lbs
- Automatically fills both paper and poly master bags
- Automatic “hands free” transfer of master bag into closing device
- Easily interfaces with Sewing Heads, Wire Tie and Taping Machines and Hot Air Sealers
- Compatible with all bagging systems
- Changeover from poly to paper master in minutes
- “Space Saver” incline conveyor for compact footprint
- Optional “Automatic Bypass” - ideal for loose stacking
- User friendly menu driven controls
- Proven performance - over 500 balers in operation



Wicketed Baggers



Robotic Palletizers



Hot Air Sealers



Master Balers

# Adjustable Master Balers AB-3000 and AB-3000HS

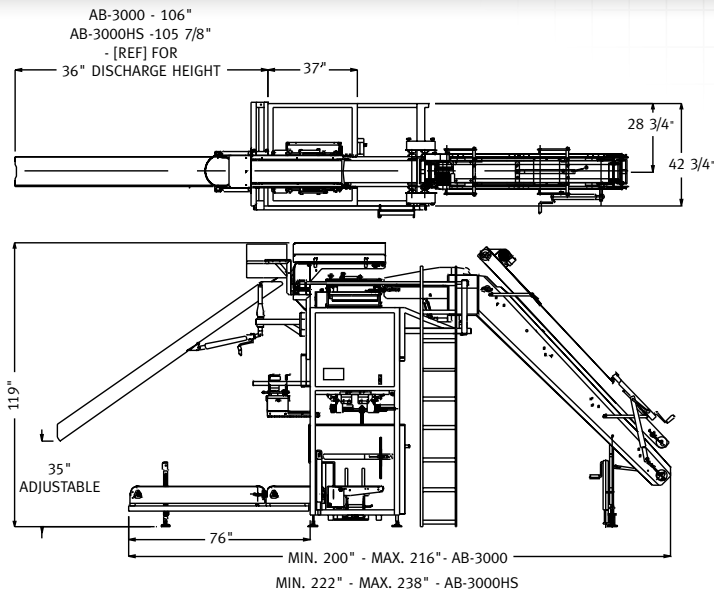

Model AB-3000 recommended for Poly Masters only.

## STANDARD FEATURES

- OMRON P.L.C. and Touch Screen
- Menu driven controls
- Infeed mechanism & discharge gates
- Bale pusher with bag transport grippers
- Bag sense, "no bag, no dump"
- Bag inflation system
- Two way adjustable accumulating chamber
- Will do 3, 4, 5, 6, 8, 10, 12, 15, 20 lb bags
- Handles poly and paper master bags\*\*\*
- Variable speed incline/accelerator conveyor assembly with JMC Space Saver Incline
- Product decelerator to eliminate bounce
- NEMA 12 electrical "swing-away" control panel with interlock
- Take away conveyor
- Motorized Bag Saddle Conveyor (150 fpm)\*\*\*
- High speed intermediate take away conveyor with bag top conveyor\*\*\*
- Spare Parts Kit

\*\*\* Model AB-3000HS Only



**Now Available  
JMC/FANUC Robotic  
Palletizing Systems  
for total automation!**

- Speed
- Reliability
- Flexibility
- Low maintenance
- Integrated with baler

## JMC FuseAir 4 Hot Air Sealer

- Provides perfect closing system
- Low maintenance
- Uses no consumables
- Safe and easy to use
- Specifically designed for master baling
- Over 500 in use



## OPTIONAL FEATURES

- JMC 90° Drag Turn conveyor
- JMC Autofeed Mesh Bale Bag Placer
- Automatic Bypass System with access ladder, bypass conveyor, and discharge chute
- Mobility Kit
- Horizontal Alignment Conveyor
- Warning Systems

## SPECIFICATIONS

- Power: 230/460/575 volt 3 PH. 60 Hz
- Air: 6 CFM @ 80 PSI
- Approx. shipping weight: 2700 lbs.

Represented By:

Manufactured for the world market by:



## JMC AUTOMATION IN PACKAGING

3470 Mainway  
Burlington, Ontario, Canada L7M 1A8  
Toll-free: 1-800-263-5252  
If busy, call: (905) 335-4196  
Fax: (905) 335-4201  
Website: [www.jmcpackaging.com](http://www.jmcpackaging.com)